

PROSIMY O ZACHOWANIE KODU IDENTYFIKACYJNEGO
PLEASE KEEP IDENTIFICATION CODE
BITTE DEN IDENTIFIKATIONS-CODE GUT AUFBEWAHREN

- PL** INSTRUKCJA MONTAŻU
- GB** ASSEMBLY INSTRUCTION
- DE** MONTAGEANLEITUNG

ADEL

AM-ERK-350-..

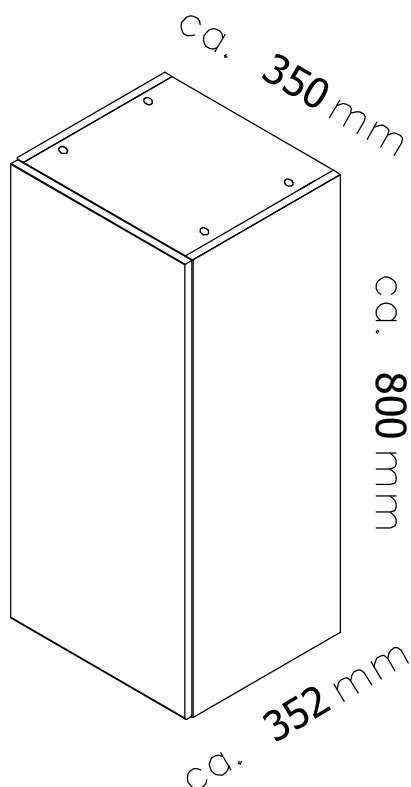

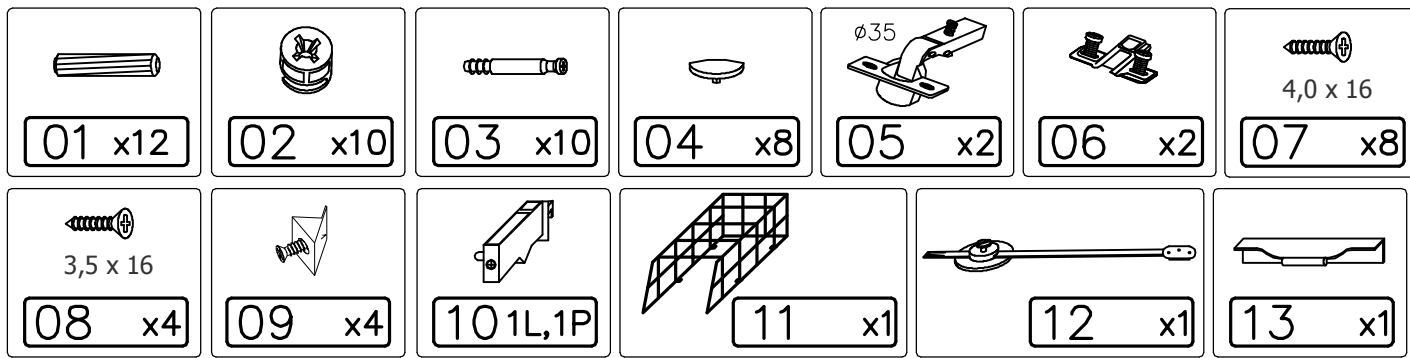

PL Drogi Kliencie
Po usunięciu folii zabezpieczającej (1) oczyść krawędzie elementu czystą, bawełnianą ściereczką (2) w celu usunięcia pozostałości po procesie lakierowania.

GB Dear Customer
Please remove the protective film (1), then clean the edges (2) with a clean cotton cloth, to remove the varnishing process residues.

DE Verehrte Kundschaft
Bitte entfernen Sie die Schutzfolie (1), reinigen sie anschließend die Kanten (2) mit einem Tuch, um eventuelle Lackrückstände zu beseitigen.

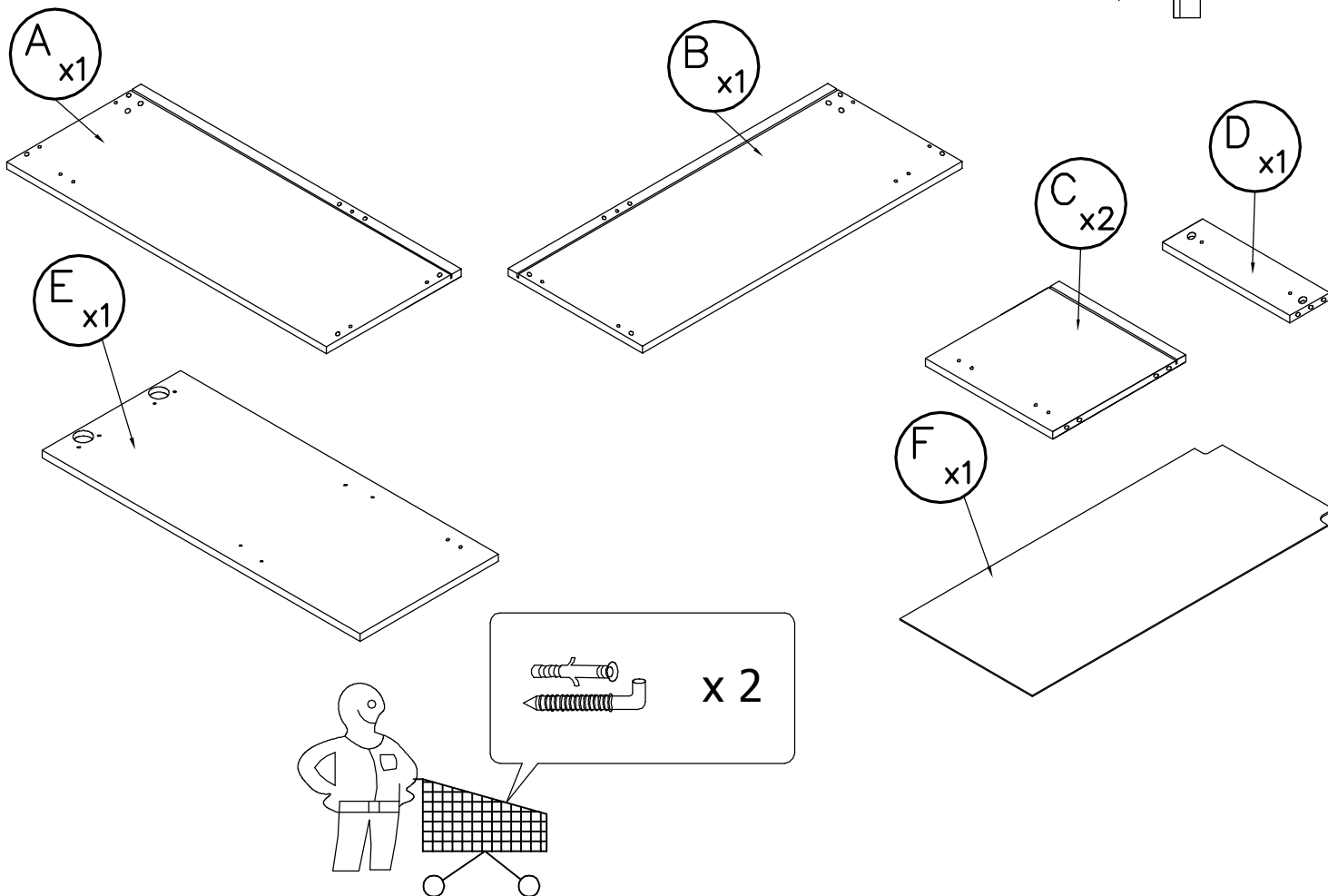
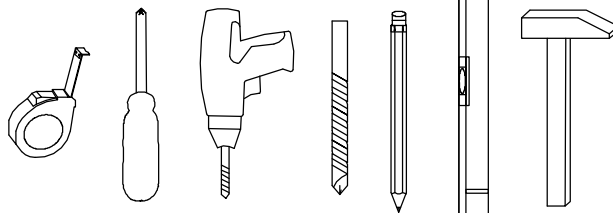
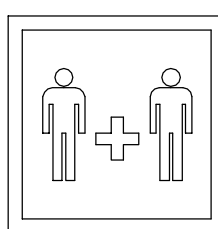
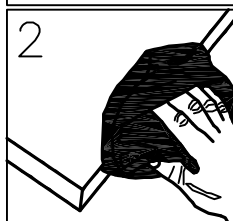
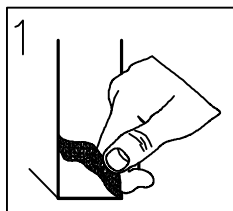

PL UWAGA: Śruby i kołki do przytwierdzenia do ściany nie są dołączone, ponieważ ich rodzaj zależy od typu ściany, przy której mebel będzie montowany. W tym zakresie należy poradzić się sprzedawcy w sklepie.

GB NOTE: Screws and wall plugs are not included, because their type depends on the type of wall, to which a piece of furniture will be installed. In this case please contact with the seller in the shop.

DE Schrauben und steckdosen sind nicht dabei, weil die Art von diesen ist abhängig von der Art der Wand, mit einem Stück Möbel wird es montiert. In diesem Fall bitte Verkäufer kontaktieren im Shop.

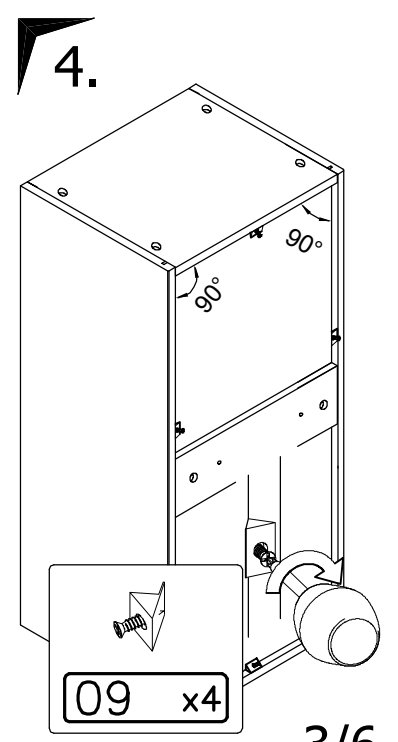
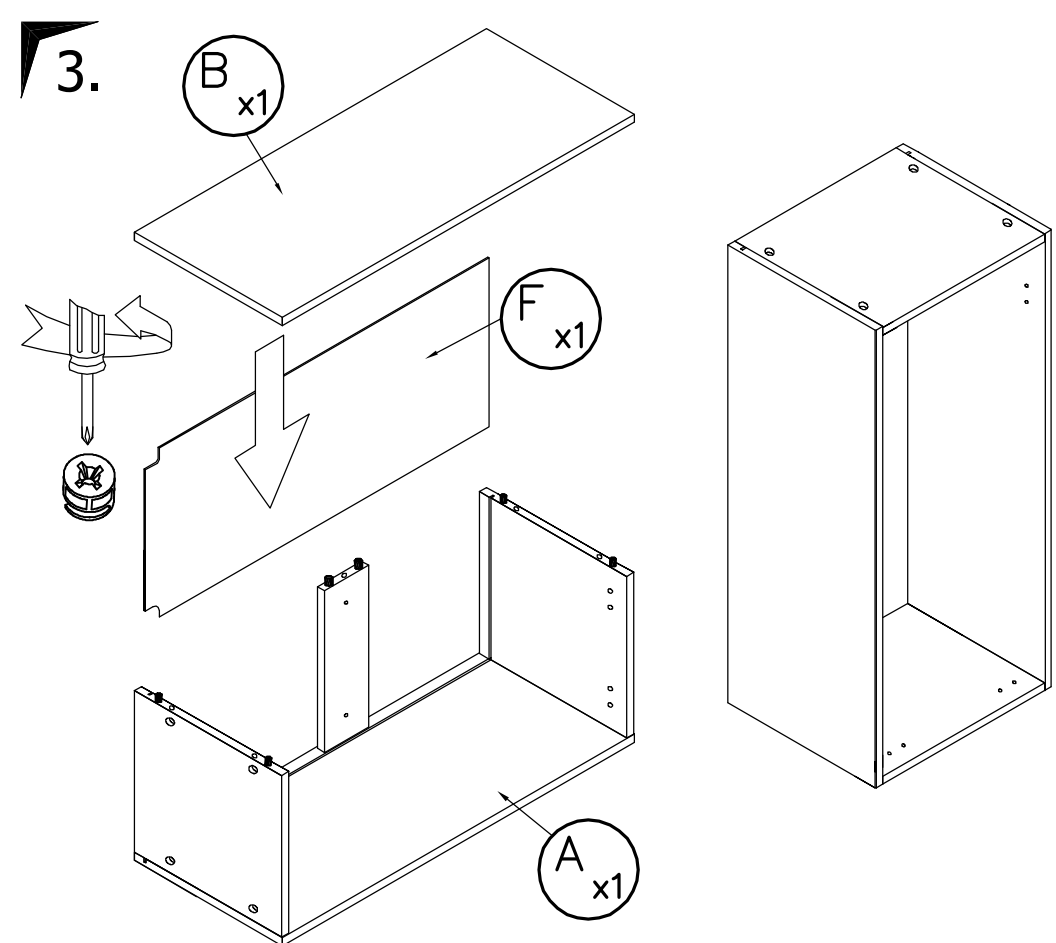
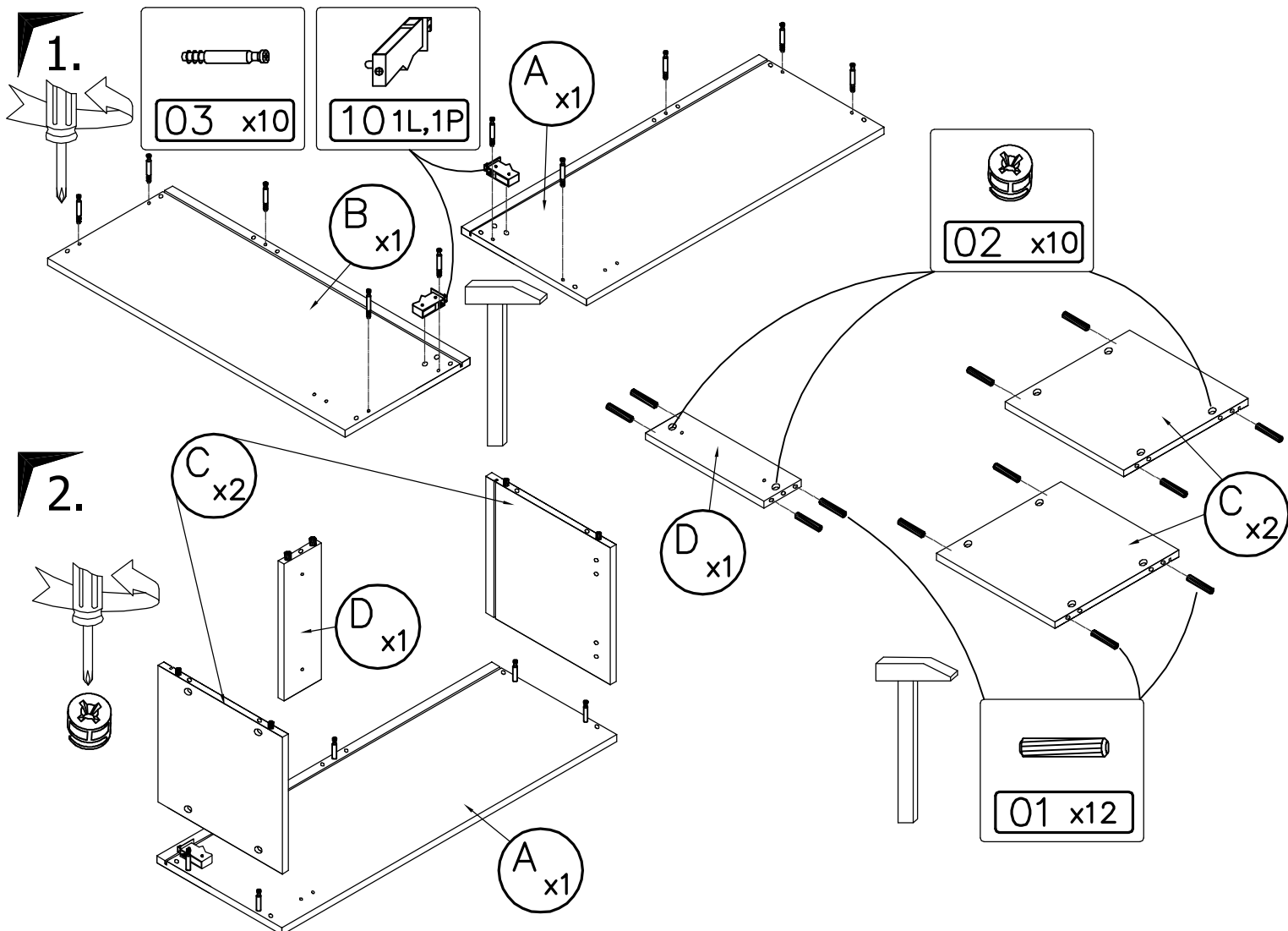

5.

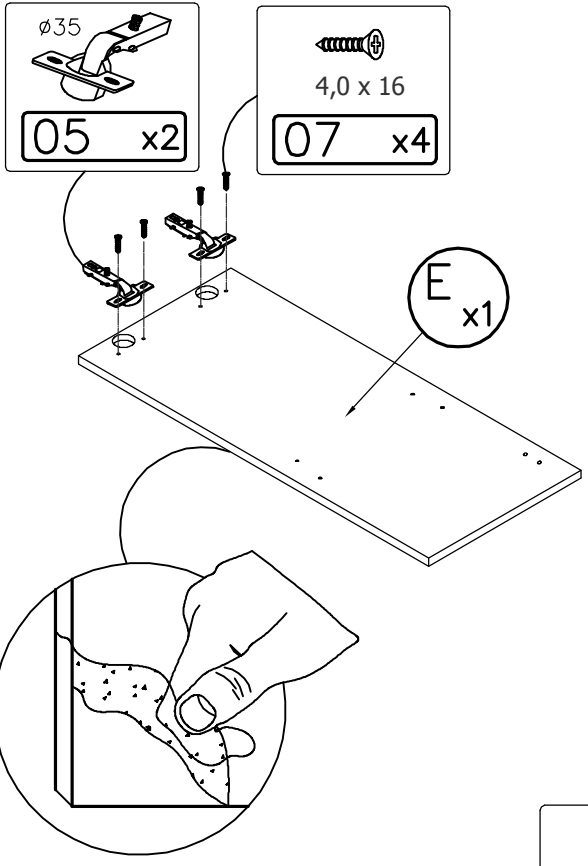

6.

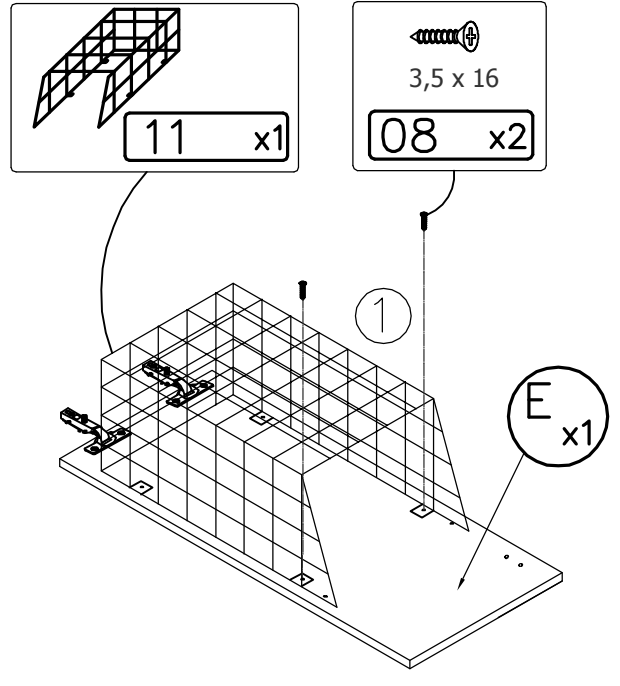

7.

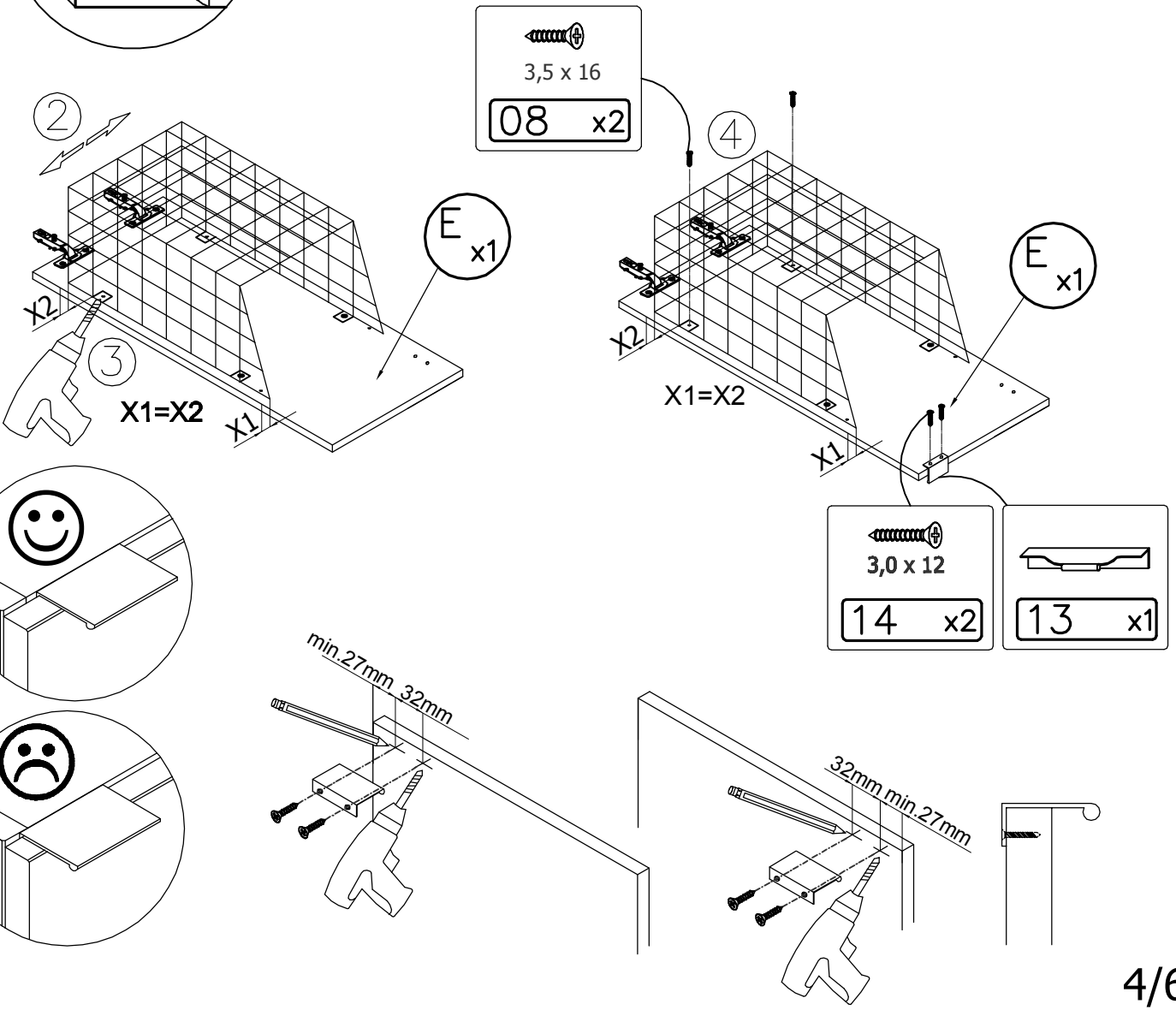

8.

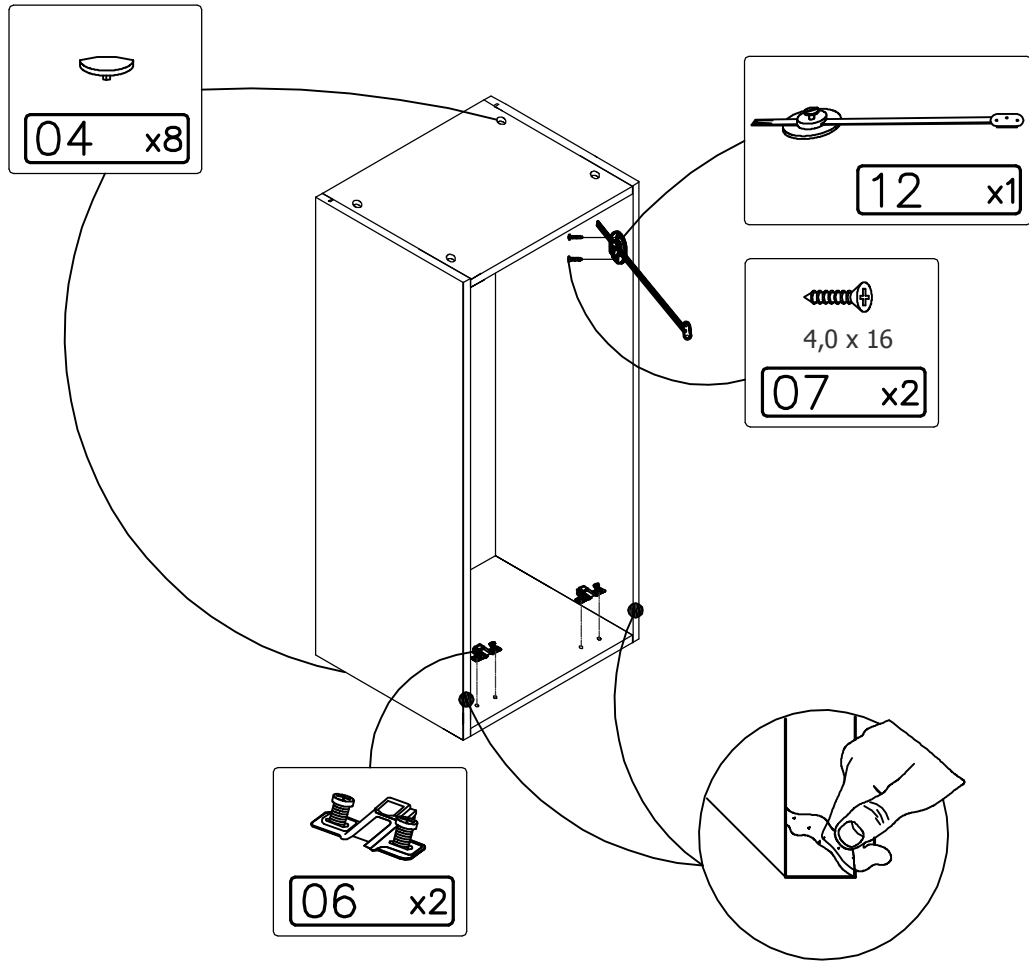

9.

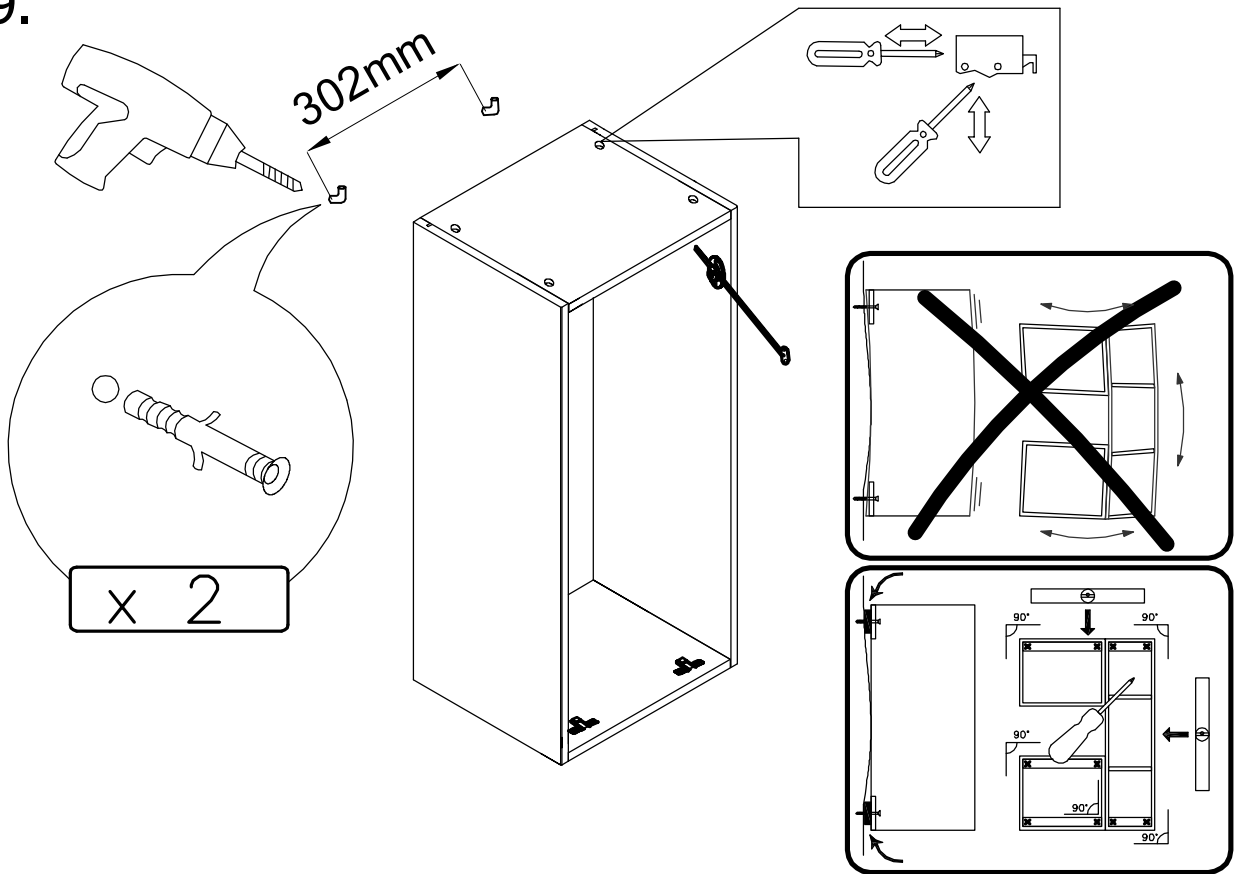

10.

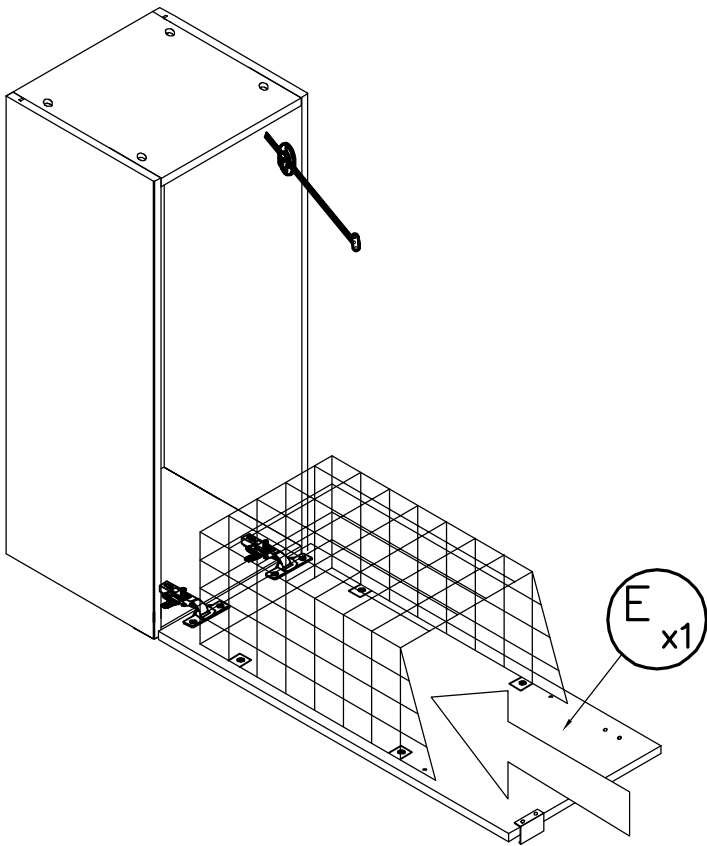

11.

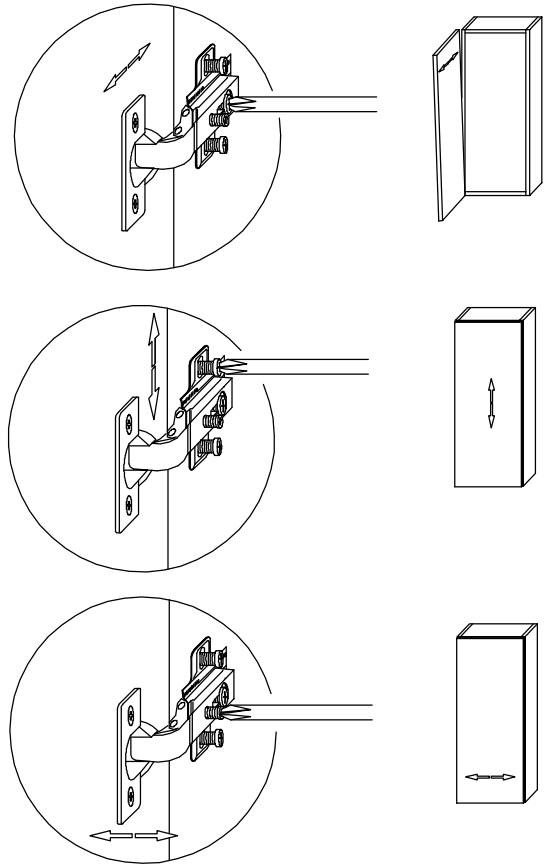

12.

