

AM-VUM-502
AM-VUM-602
AM-VUM-802

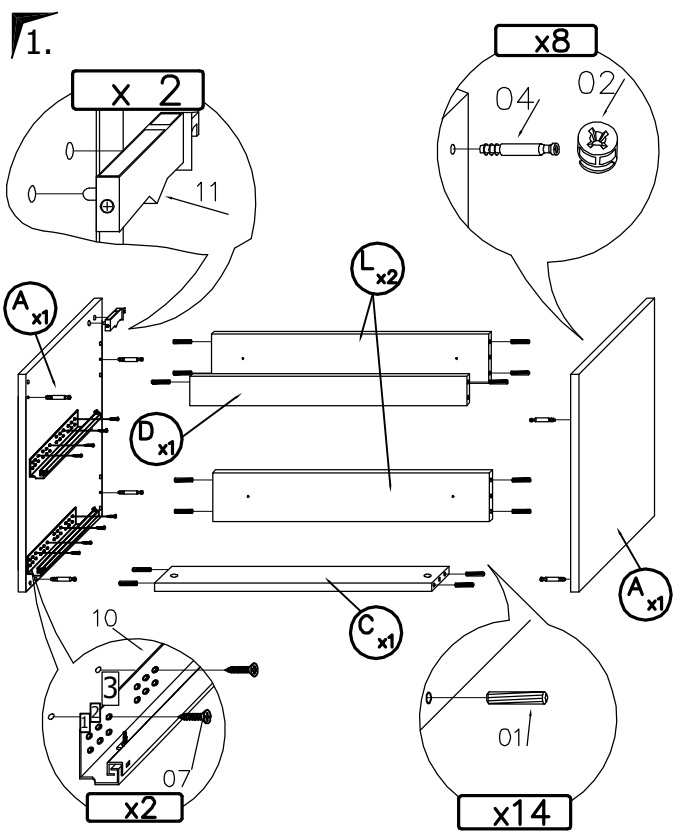

Potrzebne narzędzia
Required Tools
Benötigte Werkzeuge

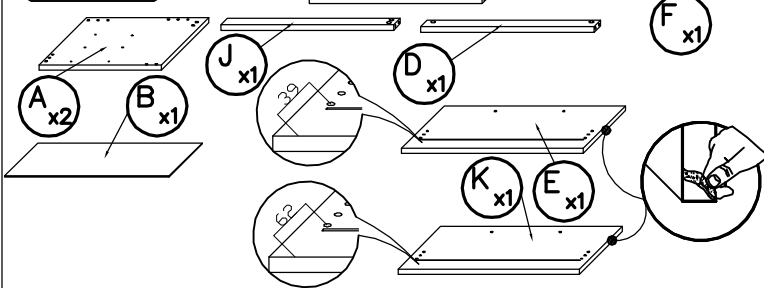
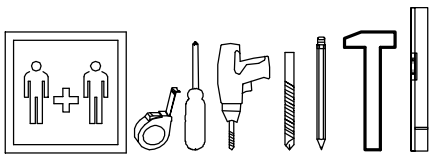

PROSIMY O ZACHOWANIE KODU IDENTYFIKACYJNEGO
PLEASE KEEP IDENTIFICATION CODE
BITTE DEN IDENTIFIKATIONS-CODE GUT AUFBEWAHREN

Drogi Kliencie
Po usunięciu folii zabezpieczającej (1)
oczyść krawędzie elementu czystą,
bawełnianą ściereczką (2) w celu usunięcia
pozostałości po procesie lakierowania.

Dear Customer
Please remove the protective film (1), then
clean the edges (2) with a clean cotton
cloth, to remove the varnishing process
residues.

Verehrte Kundschaft
Bitte entfernen Sie die Schutzfolie (1),
reinigen sie anschließend die Kanten (2)
mit einem Tuch, um eventuelle
Lackrückstände zu beseitigen.

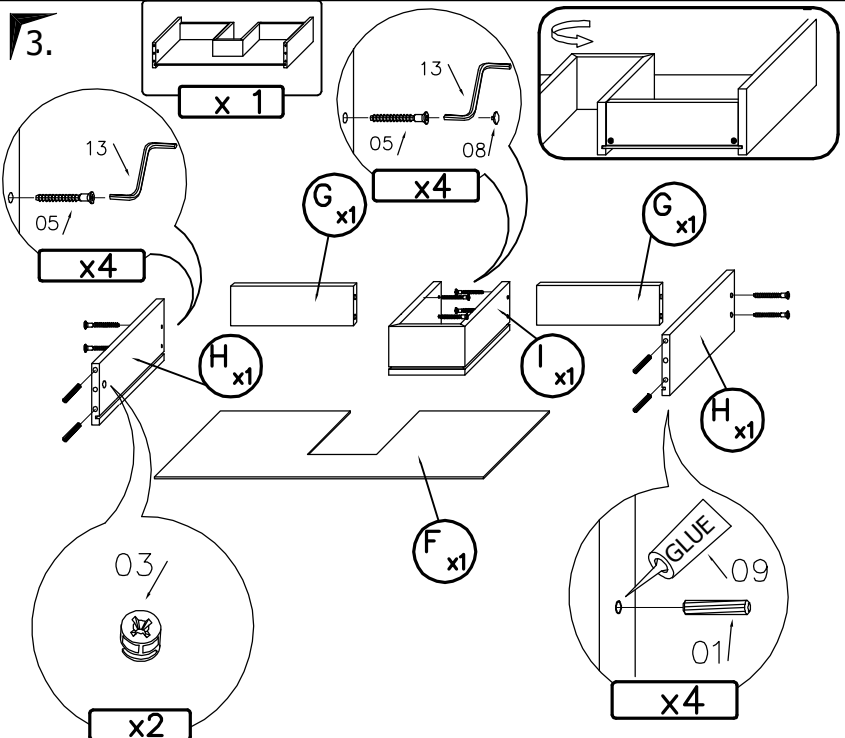
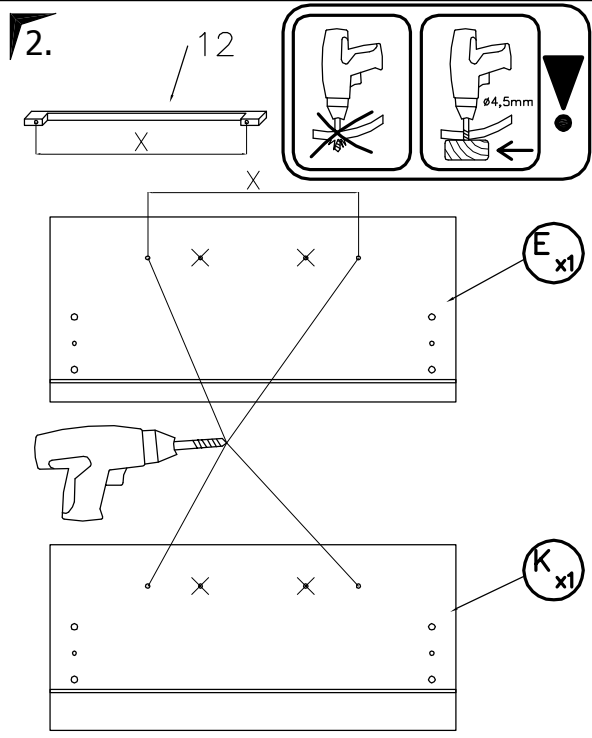
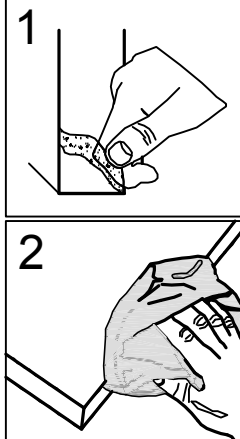

10.

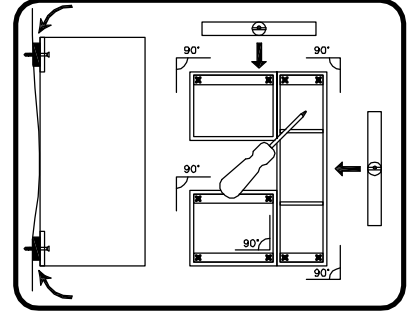
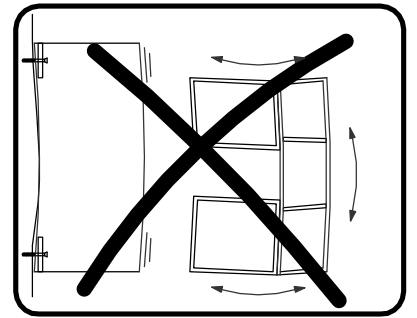
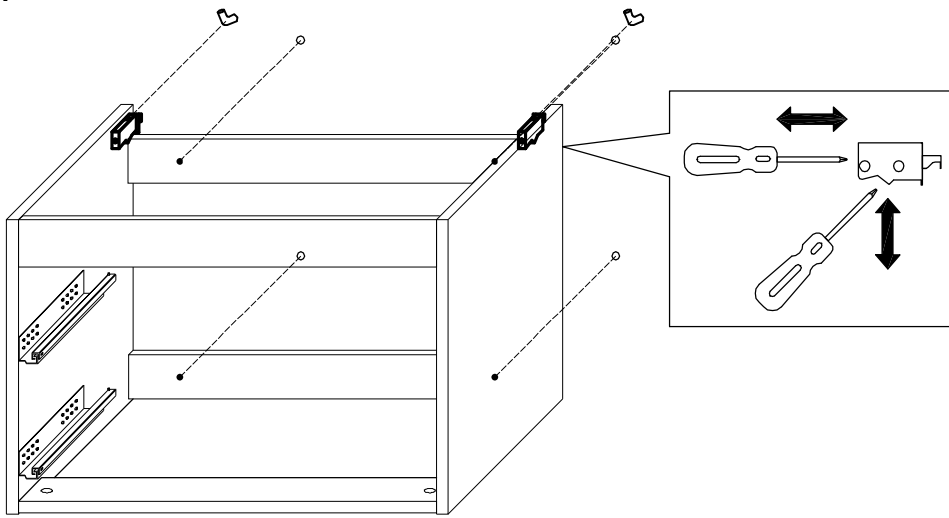

11.

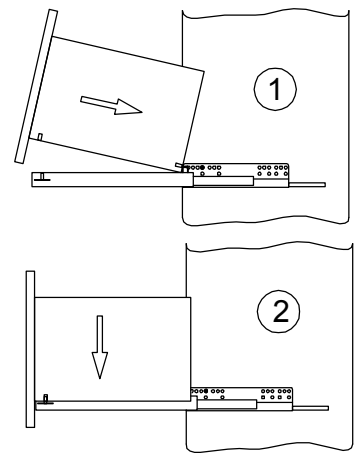
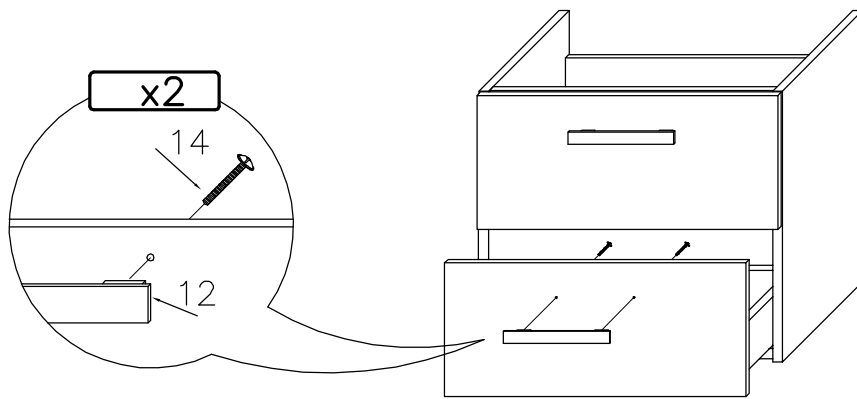

12.

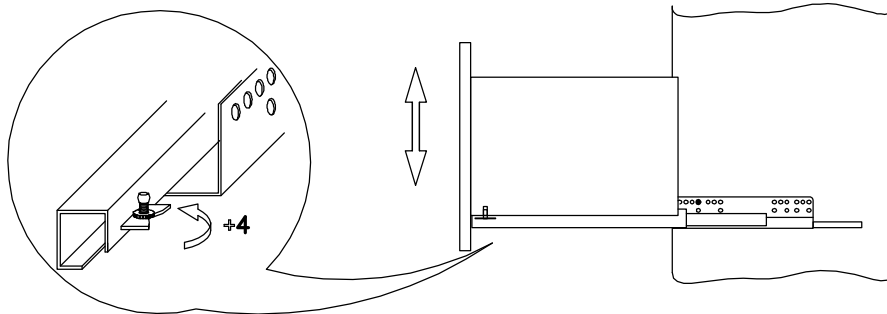

13.

